

# POWERCOM UPS

**HOM 550 / HOM 1100**

**User Manual**

*Thank you for purchasing Powercom's HOM UPS.*

## **Overview**

Powercom's HOM UPS is designed for years of trouble-free use. The UPS is a back-up power supply intended to serve computers as well as house loads. HOM-550 is rated for 550 VA/330W at 220 VAC, 50/60-Hz, & HOM-1100 is rated for 1100 VA/660W at 220 VAC, 50/60-Hz and operates on a wide range of input voltages (90 - 280V). If the input voltage goes out of range (less than 90V or more than 280V), the utility power is isolated and the UPS supplies power to the load from the external batteries. The UPS can serve inductive loads (flourescent lamps, ceiling and table fans), resistive loads (incandescent lamps), and switched mode power supply (SMPS) loads (television) apart from computers. The typical backup time with the standard battery pack at full load is approximately three hours.

## **Features:**

- Microprocessor based design.
- Ultra wide input voltage range of 90-280.
- PWM based 2 stage battery charging for long life.
- Auto restart feature for over load & short circuit.
- Generator compatible.
- Noise & Pollution free Eco-friendly design.
- Horizontal/Vertical placement design.
- Multi function LED indications & buzzer alarms.
- Overload, short circuit, over charging & deep discharge protection.
- High Temperature protection.
- Circuit Breaker protection.
- Provides extended backup time.
- Cold start feature.
- ABS plastic body,light weight.
- Designed for tropical condition.
- CPU controlled cooling fan for heat dissipation.

## **Package Contents:**

Depending on what the customer has ordered, ensure the following items have been delivered:

- UPS
- User Manual.

## **Precautions:**

1. CAUTION Use only lead-acid type rechargeable batteries, which lessens risk of injury. Other types of batteries may cause damage and injury.
2. Avoid Contact of HOM UPS with rain , snow, or liquids of any type. HOM UPS is designed for indoor.
3. Donot open HOM UPS yourself. Take it to a qualified service center when service or repair is needed.
4. WARNING: Provide ventilation to outdoors from the battery compartment.The battery enclosure should be designed to prevent accumulation & concentration of hydrogen gas at the top of the compartment.
5. Input/Output AC wiring must be no less than 18 AWG gauge copper wire. Battery cables should be no less than 10 AWG gauge. The inner diameter of the copper ring terminal which is used to connect battery cables to HOM UPS terminals should be no less than 6mm.
6. Kindly be extra careful when working with metal tools near batteries.
7. For battery installation & maintenance : Read the battery manufaturer's installation & maintenance instructions before operating.
8. Keep plenty of fresh water & soap nearby in case the battery acid contacts skin, clothing ,or eye's.

9. Avoid touching eyes while working near batteries.
10. Never smoke or allow a spark or flame in vicinity of a battery.
11. Remove personal metal items such as rings, bracelets, necklaces, & watches when working with batteries. Batteries can produce a short-circuit current high enough to make metal melt, & could cause severe burns.
12. If a remote or automatic generator start system is used, disable the automatic starting circuit or disconnect the generator to prevent accident during servicing.

**Unpacking/Inspection.**

Remove the UPS from carton. Read & retain user manual. Inspect for signs of any damage. If damage to chassis is observed, notify the dealer and return the unit to the factory. If there are no obvious signs of damage, proceed with installation.

**Installation**

**Note:** Once the unit has been completely installed, it is not desirable to move it.

**Location selection** - Ensure the area where the unit is to be placed is not in direct sunlight (surfaces may become hot). Further ensure the unit is placed in a dry area away from sources of liquids, and that the vents on each side have at least 15 cms of unobstructed clearance.

**Caution:** Installation of the HOM UPS & Batteries must be performed by a licensed and qualified electrician. Failure to comply may result in equipment damage, and may also void the warranty.

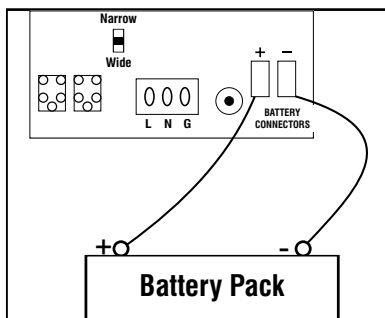

**Battery connection diagram.**

Remove power at the electricity board meter (circuit breaker panel) of the home.

Figures below shows a diagram of a typical home wiring scenario, before & after installation.

**Note:** The HOM UPS can serve computers, various other electrical devices including, inductive loads (fluorescent lamps, ceiling and table fans), resistive loads (incandescent lamps), and SMPS loads (television). The typical backup time with the primary battery pack at full load is approximately three hours.

**Caution:** Connecting the HOM UPS to a branch circuit that exceeds 10 amps may result in equipment damage.

**Note:** Home wiring to power the desired loads should be routed and connected to a single branch circuit providing a maximum of 10 amps to the circuit, Wiring must be in accordance with local electric codes and standards. Connected loads must not exceed 330/660 watts when the UPS is on battery.

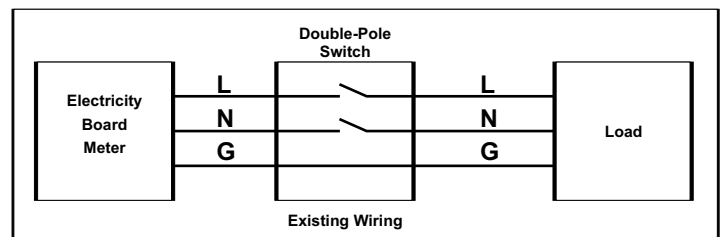

**Typical Wiring Before Installation**

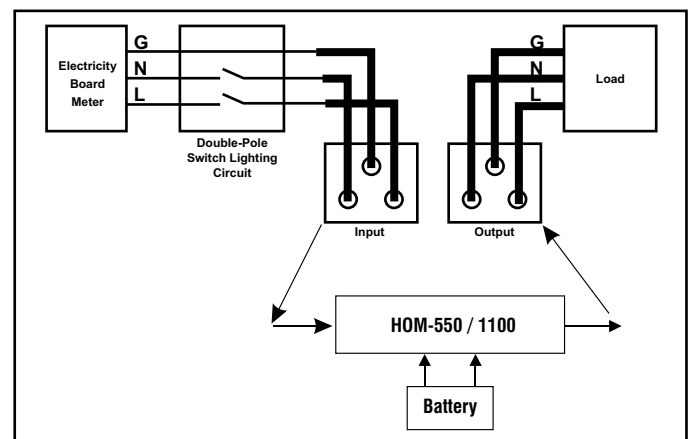

**Typical Wiring After Installation**

Once the wiring is complete and the batteries are connected to the UPS Assembly, turn on power at the Electricity Board Meter then at the Double-Pole Switch Lighting Circuit. The UPS will automatically turn on.

**Controls and Indicators**

**Front side:**

1. Power ON/OFF switch.
2. Mains ON LED (Green)
3. UPS on battery mode LED (Amber)
4. Battery fault/overload LED (Red)
5. Over temperature LED (Red)

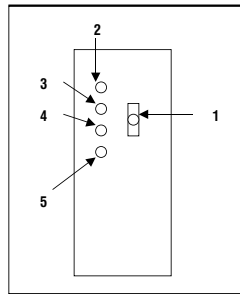

**Back side:**

6. Battery connectors + -
7. Mains input connectors, Line(L), Neutral(N), Ground(G).
8. 2 x 5pin round output sockets.
9. Wide/ Narrow selection switch.
10. I/P circuit Breaker.

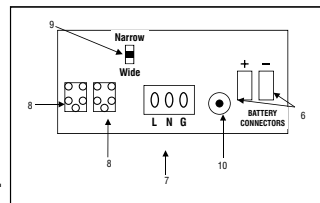

**Auto restart feature:**

In the case of a sustained overload, the UPS will be turned off automatically after one minute, and will wait in the fault state for a minute. After that, it will restart again. If the overload still persists, the UPS will be turned off again after one minute, and will wait in fault state for one minute and restart again. In the

same way, it will try for five restarts. If the overload still persists, it will stay in fault state permanently until the unit is restarted with push button.

**Generator & Inverter compatible:** The POWERCOM HOM - Series UPS are generator & inverter compatible.

**Narrow / Wide Selection:** Select Narrow (170-280V) setting for Computers and General Electronic Device. Choose wide mode (90-280V) only when using daylight lamps, fan etc.

**Troubleshooting**

**Note:** If the HOM UPS causes interference with a television while **ON-BATTERY**, move the television at least 3 feet away from the UPS. Use the information provided below to diagnose HOM UPS problems. If any abnormal situations occur that are not listed above, please call service People immediately.

**Preventive Maintenance** - Preventive maintenance consists of inspecting the batteries for cracks and/or leakage, and checking battery fluid levels and filling the batteries (every 60 days). Clean the unit with a dry cloth. Do not use liquids when cleaning.

**Troubleshooting :**

Problem	Possible Cause	Remedy
No LED display	1. Battery Weak. 2. Battery defect. 3. Power Switch is not pressed.	1. Re-charge battery cable and DC input connection. 2. Battery replacement. 3. Press and hold power switch.
Mains normal but still UPS works in battery mode	1. AC input not connected. 2. Input circuit breaker is tripped.	1. Check AC input connection. 2. Reset the input circuit breaker.
Alarm buzzer beeps specified continuously	1. Overload.	1. Verify that the load matches the capability in the specs. Reduce some non-critical load
Back up time is shortened	1. Overload 2. Battery voltage is too low.	1. Remove some non-critical load. 2. Charge battery for 12 hours or more.

**Specifications:**

Powercom HOM UPS Technical Specifications

MODEL		HOM- 550	HOM-1100
Capacity	VA/W	550VA/330W	1100VA/660W
AC input	Input Voltage I/P voltage range  I/P Frequency	220V 90-280V wide, 170-280V narrow 50/60Hz auto	220V 90-280V wide, 170-280V narrow 50/60Hz auto
Output on battery	Voltage Frequency Efficiency(AC-AC) Efficiency(DC-AC)	220V +- 5 % 50Hz +- 0.2 Hz >95% >80%	220V +- 5 % 50Hz +- 0.2 Hz >95% >80%
Protection		Auto restart on overload. I/P Circuit breaker protection. Overload, short circuit, over charging and deep discharge protection	Auto restart on overload. I/P Circuit breaker protection. Overload, short circuit, over charging and deep discharge protection
Battery	DC bus External	12V 1 x 150AH (Not included in the pack)	24V 2 x 150AH (Not included in the pack)
Transfer time	Mains-to-Inverter	8ms typical	8ms typical
Indicators		Green LED blinks or lights steadily Battery mode Yellow LED lights Overload/Fault Red LED blinks/steady Overload temperature shut down LED	Green LED blinks or lights steadily Battery mode Yellow LED lights Overload/Fault Red LED links/steady Overload temperature shut down LED
Audible alarm	Low battery Overload Fault	Buzzer every 2 sec Buzz every 0.5 sec Buzz continuous	Buzzer every 2 sec Buzz every 0.5 sec Buzz continuous
D*W*H mm Net Wt Kgs		265 X 225 X 80 2 KGs	265 X 225 X 80 2.3 KGs

**Warranty**

Powercom warrants its products to be free from defects in materials and workmanship under normal use and service for 1 year for the UPS. Its obligation under this warranty is limited to repairing or replacing, at its sole option, any such defective products. To obtain service under warranty you must obtain a Return Material Authorization (RMA) number from Asia Powercom Technical Support or an Asia Powercom Service Center. The defective unit must be returned with an RMA number, with transportation charges prepaid and it must be accompanied by a brief description of the problem and proof of date and place of purchase. This warranty applies only to the original purchaser.

**Contact Information**

[www.asiapowercom.com](http://www.asiapowercom.com)

email: [sales@asiapowercom.com](mailto:sales@asiapowercom.com)